

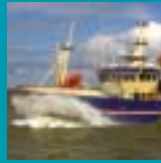

CJC™ Filter Separator

Solutions for separation of water, removal of particles, adsorption of oxidation by-products and varnish from oils



Intended for:

- Diesel Oils
- Gear Oils
- Hydraulic Fluids
- Various Lube Oils

Application examples:
Marine, Off-shore, Fishing,
Light and Heavy Industry



Oil Maintenance



1

The Problem

80% of all breakdowns in oil systems are related to particle and water contamination of the oil

Problems caused by contamination

Water Contaminated Oil



Abrasion



Corrosion /Rust

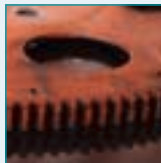

Resin/Varnish

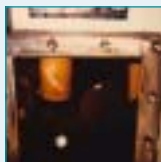

The most common types of wear caused by contamination:

"Sandblasting"

When particles subjected to high flow velocity are catapulted against metal parts, they destroy the metal surfaces and generate new particles.



Cavitation

Cavitation occurs in areas where water is present and oil is compressed; the water implodes, causing the metal surfaces to crackle and release more particles.

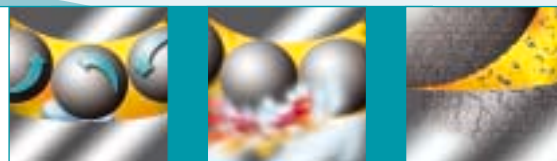

Grinding

When hard particles are wedged between movable metal parts, the metal surfaces may deteriorate and be open for further chemical subversion.



Particle and water contamination of an oil system will lead to various problems which can cause machinery breakdowns, frequent repairs of equipment and reduced oil lifetime. This will result in inefficient production, unnecessary expenses for repairs and frequent oil changes.

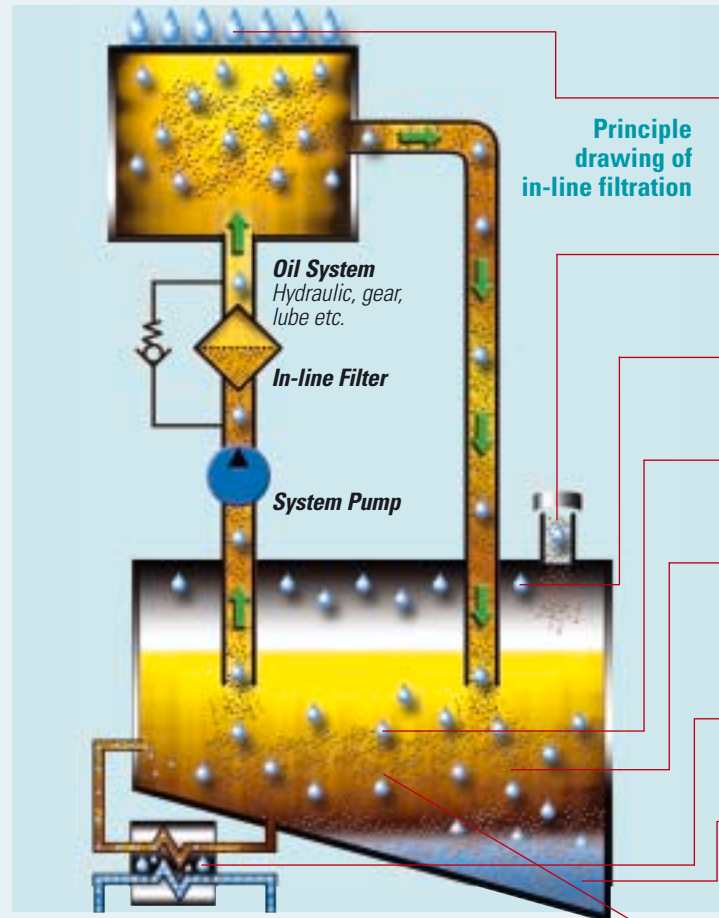

Contamination Sources:

External Environment

Water from the external environment is ingressing the system via the elements, high-pressure water blasting, washing etc.

Air Vent

Particles and water is ingressing through the air vent

Internal Environment

Water condensate in the oil reservoir

Water Produced by Oxidation

High temperature + dirty oil = Acid, water and resin

Rust/Corrosion

Water instigates the formation of rust particles which with resin and particles are accumulated in the oil reservoir

Cooler Leaking Water

A leaking cooler results in water entering the oil reservoir

The water is gathering in the bottom of the oil reservoir

Millipore membrane

Sample taken before off-line filtration



2

The Solution

Water and particle free oil through off-line filtration and separation

PTU1
15/25



The CJC™ Filter Separators combine depth filtration with water separation and are used for water contaminated lubricating and hydraulic oils.

PTU2
27-27



PTU3
27-54



PTU3
27-81



PTU3
4x
27/108



The Coalescing Principle

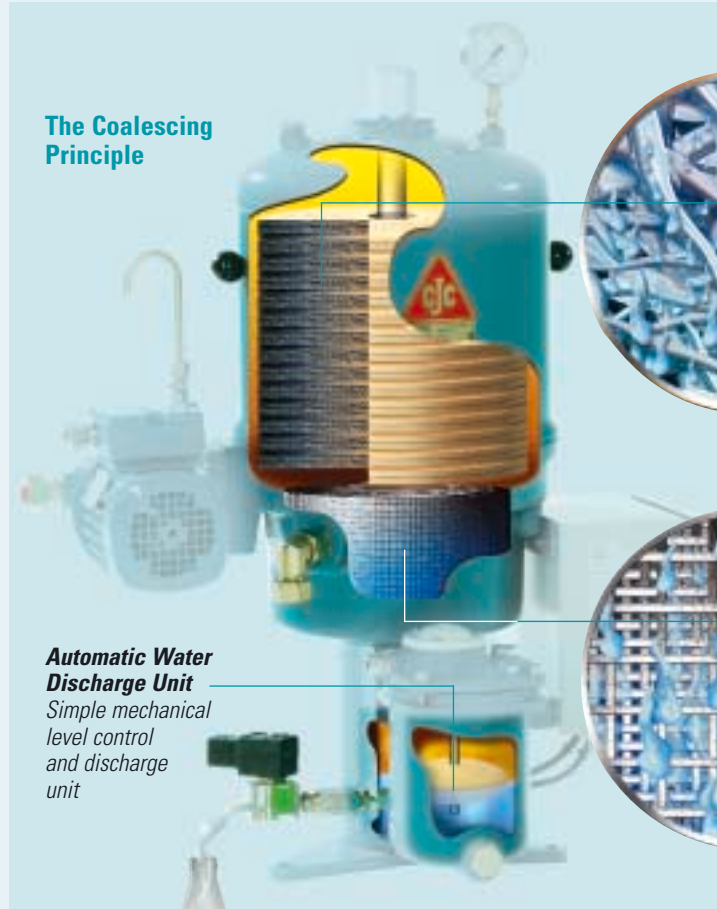

Coalescing of Water in the CJC™ Fine Filter Insert

The coalescing process starts in the filter insert. On their way through the cellulose fibres microscopic water particles aggregate into water droplets, sinking down into the coalescing element

Separation of Water in the CJC™ Coalescing Element

The droplets aggregate (coalesce) in the coalescing element and settle in the bottom of the housing and filter base

Automatic Water Discharge Unit

Simple mechanical level control and discharge unit

Removal of Particles

Particles down to 0.8 μm are retained in the filter mass



Adsorption of Oxidation By-Products

Resin in the oil is attracted to the polar fibres of the filter mass and are retained there



3

The Result

Less maintenance, increased productivity and lower energy consumption

Benefits and advantages of using CJC™ Filter Separators

The benefits that you get when implementing a CJC™ Filter Separator will have a positive effect on your maintenance budget as well as increase your productivity and reduce your energy consumption.

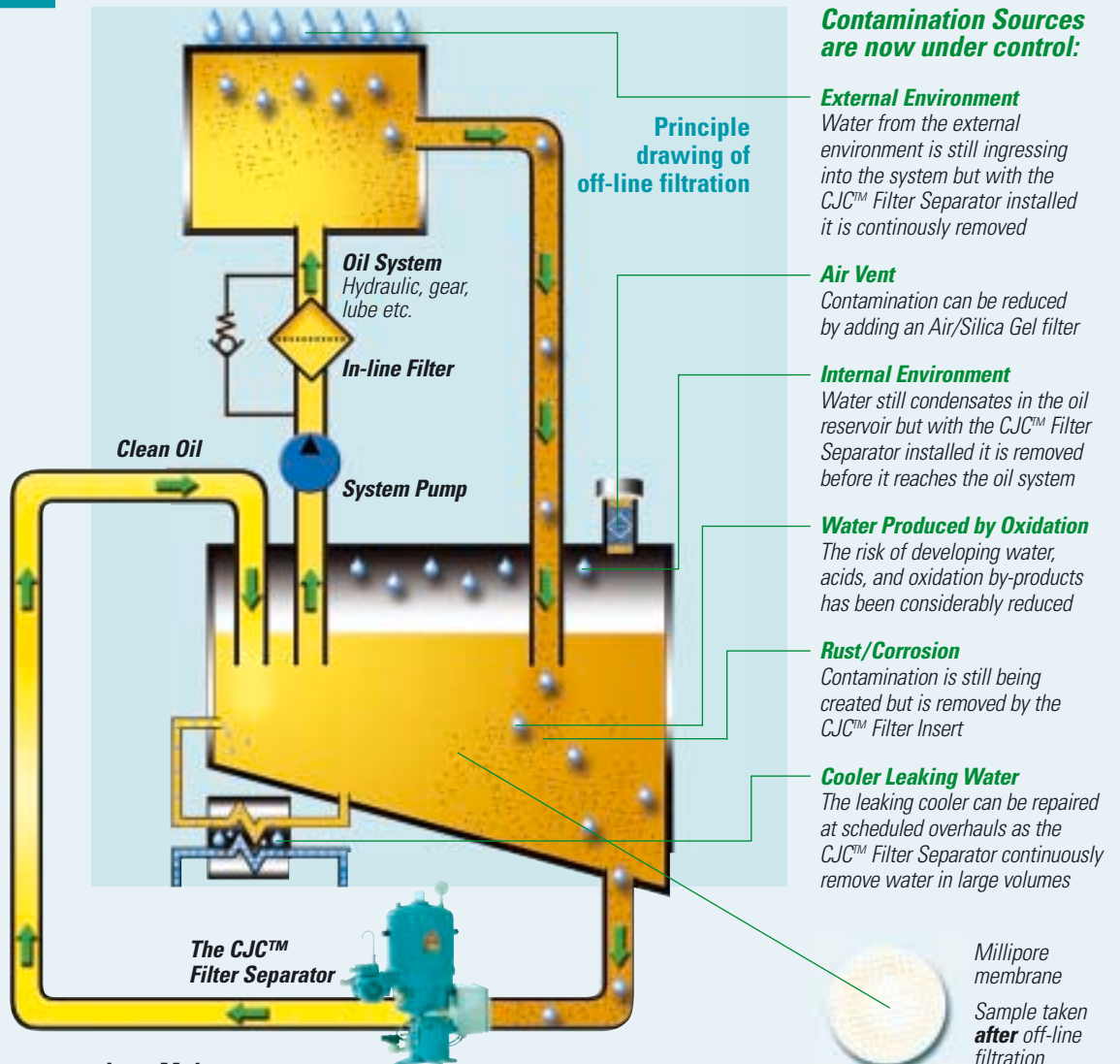

Less Maintenance

- Less wear and increased lifetime of components, oil and filter inserts
- Longer time between service intervals
- Enhanced operational precision

Increased Productivity

- Fewer unplanned breakdowns and stops of production
- Leaking coolers can be repaired at scheduled overhauls

Lower Energy Consumption

- Lubricating capabilities remain intact and internal friction is lowered
- Reduced pressure drop over in-line filters
- Viscosity index is kept stable and efficiency is maintained

- all advantages to the total economy!





The CJC™ Filter Separator

The CJC™ Filter Separator is of uncomplicated design and almost maintenance free

Key features of the CJC™ Filter Separators

The CJC™ Filter Separators are depth filters for diesel, hydraulic and lubricating oils for all sizes of oil systems.

Pressure Gauge

When the gauge indicates a pressure drop of 2 bar, the filter insert is due for replacement

CJC™ Filter Inserts

3 micron absolute rating

Oil Inlet

Contaminated oil is entering the filter

Coalescer Element

Cleanable stainless steel

Filter Base

For collecting separated water

Main components (PTU2 27/27 Series)

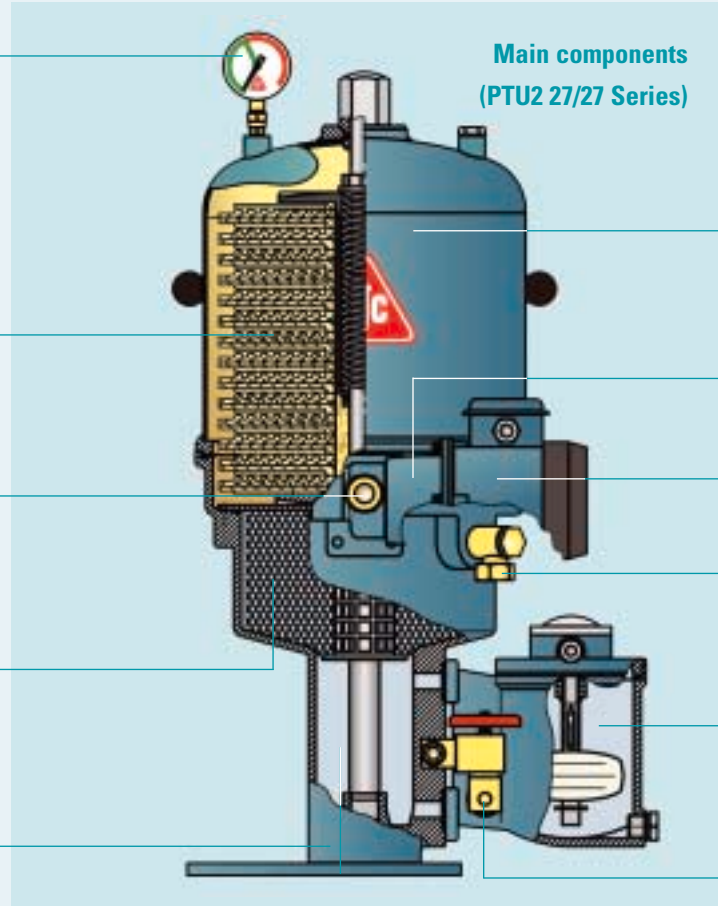

Filter Housing

Easy to remove when changing the insert

Gear Pump

Strong and reliable gear pump

Electrical Motor

Low energy consumption

Oil Outlet

Dry and particle free oil is returned to the oil system

Automatic Water Discharge Unit

Simple, mechanical level control and discharge unit

Water Drain Valve

A used sliced through filter insert (sliced half way down) showing the large dirt holding capacity



The CJC™ Filter Insert System

The modular build-up of the CJC™ Filter Inserts means that a CJC™ Fine Filter can be sized to fit any applications and requirements

The CJC™ Filter Insert Modular System

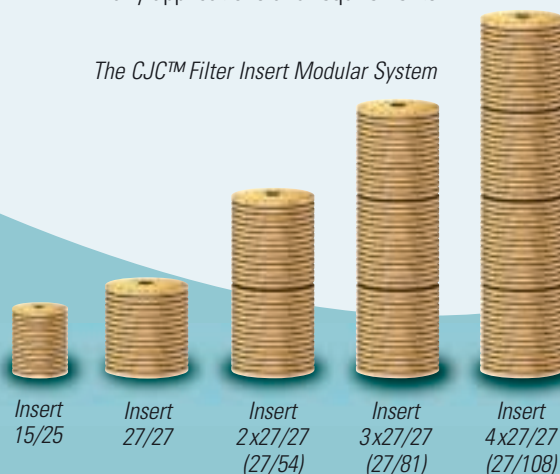



C.C.JENSEN all over the World

The CJC™ off-line Filters are distributed through our own international sales organisation and designated distributors

*CJC™
stands for
reliable
supply
world-wide*



Manufacturer

Denmark:

C.C.JENSEN A/S • Løvholmen 13 • DK-5700 Svendborg • Denmark
Tel.: +45 63 21 20 14 • Fax: +45 62 22 46 15 • E-mail: filter@cjcdk • www.cjcdk

Subsidiaries

UK:

C.C.JENSEN LTD. • Tel.: +44 1 388 420 721 • E-mail: filtration@cjcdk.co.uk • www.cjcdk.co.uk

USA:

C.C.JENSEN INC. • Tel.: +1 206 789 1710 • E-mail: ccjensen@ccjensen.com • www.cjcdk.com

Spain:

C.C.JENSEN Ibérica, S. L. • Tel.: +34 93 590 63 31 • E-mail: ccjensen.es@cjcdk • www.cjcdk.es

Poland:

C.C.JENSEN Polska Sp. z o.o. • Tel.: +48 22 648 83 43 • E-mail: ccjensen@ccjensen.com.pl • www.cjcdk.com.pl

Netherland:

C.C.JENSEN (Netherland) A/S • Tel.: +31 182 37 90 29 • E-mail: ccjensen.nl@cjcdk

Ireland:

C.C.JENSEN A/S (Ireland) • Tel.: +353 61 374 943 • E-mail: ccjensen.ie@cjcdk

Chile:

C.C.JENSEN S.L. Limitada • Tel.: +56 2 555 80 02 • E-mail: ccjensen.ch@cjcdk • www.cjcdk.cl

Greece:

C.C.JENSEN Greece LTD. • Tel.: +30 210 42 81 260 • E-mail: ccjensen.gr@cjcdk

Germany:

KARBERG & HENNEMANN GmbH & Co. KG • Tel: +49 40 85 31 09 0 • E-mail: info@karberghennemann.com

France:

KARBERG & HENNEMANN sarl • Tel: +33 1 48 17 76 85 • E-mail: info@karberghennemann.fr

Italy:

KARBERG & HENNEMANN srl • Tel: +39 059 29 29 498 • E-mail: info@karberghennemann.it

China:

C.C.JENSEN A/S China • Tel: +86 139 115 616 82 • E-mail: jp.cn@cjcdk

Your local CJC™ distributor

Oil Maintenance

We are represented all over the world by distributors. Find your nearest distributor on our website: www.cjcdk - or give us a call.

Head office:

C.C.JENSEN A/S • Denmark
Løvholmen 13 • DK 5700 Svendborg
Tel. +45 63 21 20 14 • Fax: +45 62 22 46 15
E-mail: filter@cjcdk • www.cjcdk

